

\mathcal{H}_∞ DIA Control of a Magnetic Bearing Considering Rotor Unbalance

Hiroki Seto*[†] and Toru Namerikawa*^{††}

*Nagaoka University of Technology, 1603-1 Kamitomioka, Nagaoka, Niigata 940-2188, JAPAN,
Phone +81-258-47-1611 ext.7311, Facsimile +81-258-47-9770

Email:[†]seto@stn.nagaokaut.ac.jp, ^{††}toru@nagaokaut.ac.jp

Abstract This paper deals with an \mathcal{H}_∞ DIA control system design of a magnetic bearing considering periodic disturbance. \mathcal{H}_∞ control problem which treats a mixed Disturbance and an Initial state uncertainty Attenuation (DIA) control is expected to provide a good transient property, and we confirmed that DIA control has a good rotational performance by some experiments.

On the other hand, active magnetic bearing allow contact free suspension of rotors and they are used for various industrial purposes. We derive a mathematical model of the magnetic bearing which has complicated rotor dynamics and nonlinear magnetic property.

In this paper, we propose a modified control system design of \mathcal{H}_∞ DIA control in order to consider the periodic disturbance for the magnetic bearings. In fact, we get a controller taken an integral property at specified frequency by adding a frequency weighting function in generalized plant. Experimental results show that the proposed robust control approach is effective for improving rotational performance.

Keywords: \mathcal{H}_∞ DIA Control, Magnetic Bearing, Unbalance, Periodic Disturbance, Rotational Performance

1. Introduction

Active magnetic bearings are used to support and maneuver a levitated object, often rotating, via magnetic force. Because magnetic bearings support rotors without physical contacts, they have many advantages, e.g. frictionless operation, less frictional wear, low vibration, quietness, high rotational speed, usefulness in special environments, and low maintenance. On the other hand, disadvantages of magnetic bearings include the expense of the equipment, the necessity of countermeasures in case of a power failure, and instability in their control systems. However, there are many real-world applications which utilize the advantages outlined above.

By the way, \mathcal{H}_∞ control has proven its effect for robust control problem and it has been applied to a variety of industrial products. a mixed Disturbance and an Initial-state uncertainty Attenuation (DIA) control is expected to provide a good transient characteristic as compared with conventional \mathcal{H}_∞ control⁽²⁾. Recently, hybrid/switching control are actively studied, this method might be one of the most reasonable approach to implement them.

We applied an \mathcal{H}_∞ DIA control to a magnetic bearing, and confirmed that this control has a better transient response⁽³⁾. But in its research, we did not consider a rotation of the rotor. Therefore, The goal of this paper is to improve rotational performance by considering the periodic disturbance caused by unbalance of rotor while the rotor is rotating. Many researchers have tackled the problem of unbalance vibration via magnetic bearings⁽⁴⁾⁽⁵⁾.

For that purpose, we proposed another control system design of \mathcal{H}_∞ DIA control in order to improve more ro-

tational performance of a magnetic bearing against the periodic disturbance caused by unbalance of rotor.

In this paper, we apply an \mathcal{H}_∞ DIA control system design of a magnetic bearing considering periodic disturbance. In fact, we get a controller taken an integral property at specified frequency by adding a frequency weighting function in generalized plant. First we derive a mathematical model of magnetic bearing systems considering rotor dynamics and nonlinearities of magnetic force⁽³⁾. Then we set the generalized plant which contains design parameter for uncertainty, control performance and periodic disturbance.

Experimental results show that the proposed robust control approach is effective for improving more rotational performance.

2. \mathcal{H}_∞ DIA CONTROL

Consider the linear time-invariant system which is defined on the time interval $[0, \infty)$.

$$\begin{aligned} \dot{x} &= Ax + B_1w + B_2u, & x(0) &= x_0 \\ z &= C_1x + D_{12}u \\ y &= C_2x + D_{21}w \dots\dots\dots (1) \end{aligned}$$

where $x \in R^n$ is the state and $x_0 = x(0)$ is the initial state; $u \in R^r$ is the control input; $y \in R^m$ is the observed output; $z \in R^q$ is the controlled output; $w \in R^p$ is the disturbance. The disturbance $w(t)$ is a square integrable function defined on $[0, \infty)$. A , B_1 , B_2 , C_1 , C_2 , D_{12} and D_{21} are constant matrices of appropriate dimensions and satisfies that

- (A, B_1) is stabilizable and (A, C_1) is detectable
- (A, B_2) is controllable and (A, C_2) is observable
- $D_{12}^T D_{12} \in R^{r \times r}$ is nonsingular

- $D_{21}D_{21}^T \in R^{m \times m}$ is nonsingular

For system (1), every admissible control $u(t)$ is given by linear time-invariant system of the form

$$\begin{aligned} u &= J\zeta + Ky \\ \dot{\zeta} &= G\zeta + Hy, \quad \zeta(0) = 0 \dots\dots\dots (2) \end{aligned}$$

which makes the closed-loop system given internally stable, where $\zeta(t)$ is the state of the controller of a finite dimension; J, K, G and H are constant matrices of appropriate dimensions. For the system and the class of admissible controls described above, consider a mixed-attenuation problem state as below.

Problem 1 \mathcal{H}_∞ DIA control problem

Find an admissible control attenuating disturbances and initial state uncertainties in the way that, for given $N > 0$, z satisfies

$$\|z\|_2^2 < \|w\|_2^2 + x_0^T N^{-1} x_0 \dots\dots\dots (3)$$

for all $w \in L^2[0, \infty)$ and all $x_0 \in R^n$, s.t., $(w, x_0) \neq 0$. Such an admissible control is called the **Disturbance and Initial state uncertainty Attenuation (DIA) control**.

In order to solve the DIA control problem, we require the so-called Riccati equation conditions.

3. SYSTEM AND MODELING

The experimental setup of the magnetic bearing system is shown in Fig.1. The controlled plant is a 4-axis controlled type active magnetic bearing with symmetrical structure. The axial motion is not controlled actively. The electromagnets are located in the horizontal and the vertical direction of both sides of the rotor. Moreover, hall-device-type gap sensors are located in the both sides of the vertical and horizontal direction.

In order to derive a nominal model of the system under the some assumptions⁽⁶⁾. The assumptions are not strong and suitable around the steady state operation, but if the rotor spins at super-high speed, these assumptions will be failed. Based on these assumptions and a mathematical model of a magnetic bearing derived in⁽³⁾, we considered the periodic disturbance caused by unbalance of rotor, which synchronized with rotational frequency. The obtained result is as follows,

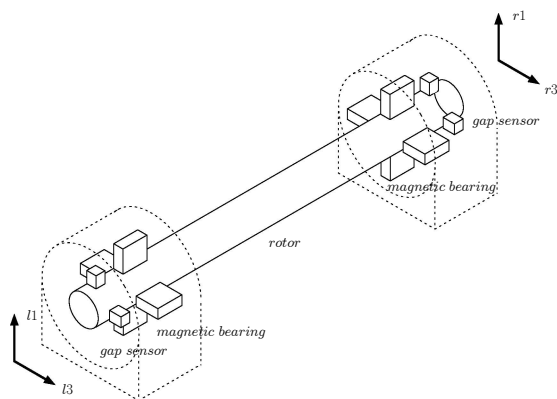

Fig. 1. Magnetic Bearing

$$\begin{aligned} \begin{bmatrix} \dot{x}_v \\ \dot{x}_h \end{bmatrix} &= \begin{bmatrix} A_v & pA_{vh} \\ -pA_{vh} & A_h \end{bmatrix} \begin{bmatrix} x_v \\ x_h \end{bmatrix} \\ &+ \begin{bmatrix} B_v & 0 \\ 0 & B_h \end{bmatrix} \begin{bmatrix} u_v \\ u_h \end{bmatrix} \\ &+ \begin{bmatrix} D_v & 0 \\ 0 & D_h \end{bmatrix} \begin{bmatrix} v_v \\ v_h \end{bmatrix} + p^2 \begin{bmatrix} E_v \\ E_h \end{bmatrix} \begin{bmatrix} v_{vh} \\ v_{vh} \end{bmatrix} \\ \begin{bmatrix} y_v \\ y_h \end{bmatrix} &= \begin{bmatrix} C_v & 0 \\ 0 & C_h \end{bmatrix} \begin{bmatrix} x_v \\ x_h \end{bmatrix} + \begin{bmatrix} w_v \\ w_h \end{bmatrix} \dots\dots\dots (4) \end{aligned}$$

$$\begin{aligned} x_v &= [g_{l1} \ g_{r1} \ \dot{g}_{l1} \ \dot{g}_{r1} \ i_{l1} \ i_{r1}]^T \\ x_h &= [g_{l3} \ g_{r3} \ \dot{g}_{l3} \ \dot{g}_{r3} \ i_{l3} \ i_{r3}]^T \\ u_v &= [e_{l1} \ e_{r1}]^T, \quad u_h = [e_{l3} \ e_{r3}]^T \\ v_v &= [v_{ml1} \ v_{mr1} \ v_{Ll1} \ v_{Lr1}]^T \\ v_h &= [v_{ml3} \ v_{mr3} \ v_{Ll3} \ v_{Lr3}]^T \\ v_{vh} &:= \begin{bmatrix} \varepsilon \sin(pt + \kappa) \\ \tau \cos(pt + \lambda) \end{bmatrix}, \quad v_{uh} := \begin{bmatrix} \varepsilon \cos(pt + \kappa) \\ \tau \sin(pt + \lambda) \end{bmatrix} \\ y_v &= [y_{l1} \ y_{r1}]^T, \quad y_h = [y_{l3} \ y_{r3}]^T \\ w_v &= [w_{l1} \ w_{r1}]^T, \quad w_h = [w_{l3} \ w_{r3}]^T \end{aligned}$$

where $I_2 \in R^{2 \times 2}$ is unit matrix, and the subscripts v and h in the vectors and the matrices stand for the vertical motion and the horizontal motion of the magnetic bearing, respectively. In addition, the subscript vh stands for the coupling term between the vertical motion and the horizontal motion, and p denotes the rotational speed of the rotor. $\varepsilon, \tau, \kappa, \lambda$ are unbalance parameters.

The equation (4) can be also expressed simply as

$$\begin{aligned} \dot{x}_g &= A_g(p)x_g + B_g u_g + D_g v_0 + p^2 E_g v_u \\ y_g &= C_g x_g + w_0 \dots\dots\dots (5) \end{aligned}$$

where $x_g := [x_v^T \ x_h^T]^T$, $u_g := [u_v^T \ u_h^T]^T$, $v_0 := [v_v^T \ v_h^T]^T$, $v_u := [v_{vh}^T \ v_{uh}^T]^T$, $w_0 = [w_v^T \ w_h^T]^T$ and A_g, B_g, C_g, D_g, E_g are constant matrices of appropriate dimensions.

4. CONTROL SYSTEM DESIGN

In this section, we design an \mathcal{H}_∞ DIA controller for the magnetic bearing system based on the derived state-space formula. Let us construct a generalized plant for the magnetic bearing control system. First, consider the system disturbance v_0 . Since v_0 mainly acts on the plant in a low frequency range in practice, it is helpful to introduce a frequency weighting factor. Hence let v_0 be of the form

$$v_0 = W_{v1}(s)w_2 \dots\dots\dots (6)$$

$$W_{v1}(s) = \begin{bmatrix} I_2 & 0 \\ I_2 & 0 \\ 0 & I_2 \\ 0 & I_2 \end{bmatrix} W_{v0}(s)$$

$$W_{v0}(s) = C_{v0}(sI_4 - A_{v0})^{-1} B_{v0}$$

where $W_{v1}(s)$ is a frequency weighting whose gain is relatively large in a low frequency range, and w_2 is a (1, 2) element of w . These values, as yet unspecified, can be regarded as free design parameters.

Let us consider the system disturbance w_0 for the output. The disturbance w_0 shows an uncertain influence

caused via unmodeled dynamics, and define

$$\begin{aligned} w_0 &= W_w(s)w_1 \dots\dots\dots (7) \\ W_w(s) &= I_4 W_{w0}(s) \\ W_{w0}(s) &= C_{w0}(sI_4 - A_{w0})^{-1} B_{w0} \end{aligned}$$

where $W_w(s)$ is a frequency weighting function and w_1 is a (1, 1) element of w . Note that I_4 is unit matrix in $R^{4 \times 4}$.

Finally, let us consider the periodic disturbance v_u . The disturbance v_u shows an uncertain influence via unbalance of rotor mass. Because of the disturbance v_u , a rotor of the magnetic bearing causes a vibration which synchronized with rotational frequency of rotor. v_u is defined as below,

$$\begin{aligned} v_u &= W_{v2}(s)w_3 \dots\dots\dots (8) \\ W_{v2}(s) &= I_4 W_{vu}(s) \\ W_{vu}(s) &= C_{vu}(sI_4 - A_{vu})^{-1} B_{vu} \end{aligned}$$

where $W_{v2}(s)$ is a frequency weighting function which has a peak of gain at specified frequency and w_3 is a (1,3) element of w .

Next we consider the variables which we want to regulate. In this case, since our main concern is in the stabilization of the rotor, the gap and the corresponding velocity are chosen i.e.,

$$\begin{aligned} z_g &= F_g x_g, \dots\dots\dots (9) \\ F_g &= \begin{bmatrix} I_2 & 0 & 0 & 0 & 0 & 0 \\ 0 & I_2 & 0 & 0 & 0 & 0 \\ 0 & 0 & 0 & I_2 & 0 & 0 \\ 0 & 0 & 0 & 0 & I_2 & 0 \end{bmatrix} \\ z_1 &= \Theta z_g, \Theta = \text{diag} [\theta_1 \quad \theta_2 \quad \theta_1 \quad \theta_2] \dots (10) \end{aligned}$$

where Θ is a weighting matrix on the regulated variables z_g , and z_1 is a (1, 1) element of z . This value Θ , as yet unspecified, are also free design parameters.

Furthermore the control input u_g should be also regulated, and we define

$$z_2 = \rho u_g \dots\dots\dots (11)$$

where ρ is a weighting scalar, and z_2 is a (1, 2) element of z . Finally, let $x := [x_g^T \quad x_{v1}^T \quad x_{v2}^T \quad x_w^T]^T$, where x_{v1} denotes the state of the function $W_{v1}(s)$, x_{v2} denotes the state of the function $W_{v2}(s)$, x_w denotes the state of the function $W_w(s)$, and $w := [w_1^T \quad w_2^T \quad w_3^T]^T$, $z := [z_1^T \quad z_2^T]^T$, then we can construct the generalized plant as in Fig.2 with an unspecified controller K .

The state-space formulation of the generalized plant is given as follows,

$$\begin{aligned} \dot{x} &= Ax + B_1 w + B_2 u \\ z &= C_1 x + D_{12} u \\ y &= C_2 x + D_{21} u \dots\dots\dots (12) \end{aligned}$$

where A , B_1 , B_2 , C_1 , C_2 , D_{12} and D_{21} are constant matrices of appropriate dimensions. Since the disturbances w represent the various model uncertainties, the effects

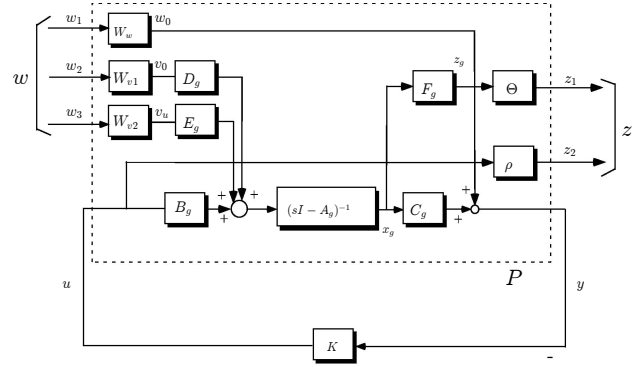

Fig. 2. Generalized Plant

of these disturbances on the error vector z should be reduced.

Next our control problem setup is defined as below.

Control problem : find an admissible controller $K(s)$ that attenuates disturbances and initial state uncertainties to achieve DIA condition in (3) for generalized plant (12).

After some iteration in MATLAB environment, design parameters are chosen as follows.

$$\begin{aligned} W_{v0}(s) &= \frac{40000}{s + 0.1} \\ W_{w0}(s) &= \frac{1.5(s + 1.07 \times 10^4)(s + 2.51 \times 10^3 \pm 4.35 \times 10^3 j)}{(s + 5.34 \times 10^4)(s + 5.0 \times 10^{-1} \pm 5.03 \times 10^3 j)} \\ W_{vu}(s) &= \frac{1000(s + 7.85 \times 10^1 \pm 1.36 \times 10^2 j)}{(s + 5.0 \times 10^{-1} \pm 1.57 \times 10^2 j)} \\ \Theta &= \text{diag} [\theta_{v1} \quad \theta_{v2} \quad \theta_{h1} \quad \theta_{h2}] \\ \theta_{v1} &= \text{diag} [0.4 \quad 0.4], \\ \theta_{h1} &= \text{diag} [0.5 \quad 0.5] \\ \theta_{v2} = \theta_{h2} &= \text{diag} [0.0005 \quad 0.0005] \\ \rho &= 8.0 \times 10^{-7} I_4 \end{aligned}$$

$W_{w0}(s)$ represents an uncertainty for the 1st bending mode of the rotor at the resonance frequency 800[Hz]. W_{vu} has a high gain at specified frequency in order to attenuate the vibration via unbalance of rotor. In this paper, W_{vu} has a peak of gain at 25[Hz], therefore we can attenuate the amplitude of the vibration at 1500[rpm] as rotational speed of rotor.

Direct calculations yield the 36-order \mathcal{H}_∞ DIA central controller K and its frequency response is shown in Fig.3. We can see that this controller has a peak of gain at 25[Hz]. In other word, we can get a controller as it has a peak of gain at specified frequency. Then, this designed DIA controller is expected to have a good rotational performance in some experiments.

5. EVALUATION BY EXPERIMENTS

We conducted control experiments to evaluate properties of the designed \mathcal{H}_∞ DIA controller.

The objective of this experimental comparison is to evaluate control performance for rotational performance. The experimental results are shown in Figs.4,5.

The control performance for rotational rotor is evaluated with a controller without considering unbal-

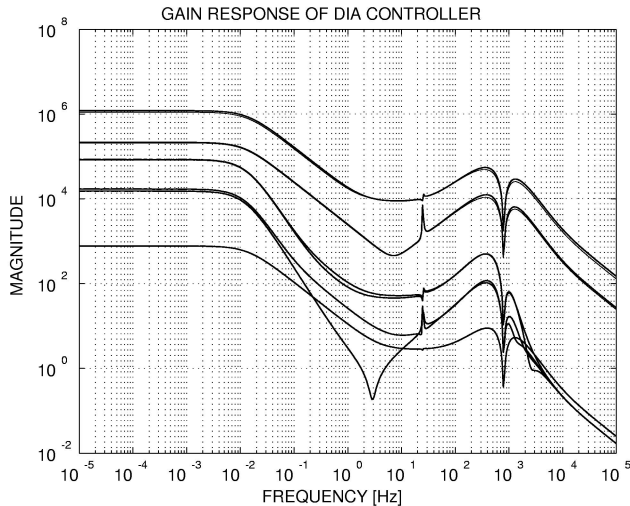

Fig. 3. Frequency Responses of \mathcal{H}_∞ DIA Controller

ance(referred to as K1) and a controller with considering unbalance(referred to as K2). As the rotational experiments, we carried out the free-run tests with varying rotational rotor speed from 3000[rpm] to 0[rpm]. Then we prepared a \mathcal{H}_∞ DIA controller which have a peak of gain at 25[Hz].

In Figs.4,5, the horizontal axes show time and the rotational speed changed from 3000[rpm] to 0[rpm]. The vertical axes show the vertical displacement of the left side of the rotor. By comparison Fig.4 with Fig.5, we can see that Fig.5 has a partial attenuation of unbalance rotor vibration around 25[Hz].

In Fig.5, a frequency that the amplitude of rotor vibration is the best attenuated in actually is not same as a frequency specified by the weighting functions W_{vu} . As this reason, if the vibration of specified frequency appears, it is necessary to spend a little time until attenuating its vibration. Then, for varying the rotational rotor speed momentarily, the amplitude of vibration is increase as soon as the amplitude become smallest. Against this phenomenon, if we carry out an experiment such that rotational rotor speed is constant, the amplitude of vibration is able to avoid increasing continuously.

The proposed \mathcal{H}_∞ DIA controller shows a better rotational performance for varying rotational speed tests.

6. CONCLUSION

This paper dealt with an \mathcal{H}_∞ DIA control system design of a magnetic bearing considering periodic disturbance.

First we derived a mathematical model of magnetic bearings, and constructed a generalized plant considering the periodic disturbance caused by unbalance of rotor. Then we set some design parameters for uncertainty, control performance and periodic disturbance in the generalized plant.

Finally, several experimental results of rotational performance with varying rotational speed showed that the proposed \mathcal{H}_∞ DIA robust control approach is effective for improving the rotational performance.

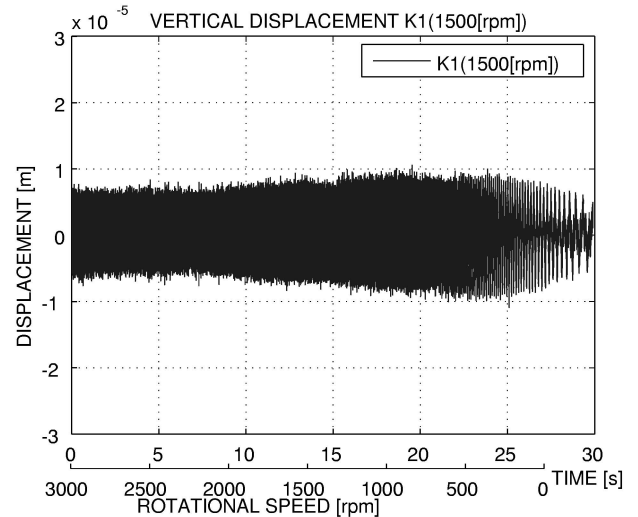

Fig. 4. Displacement of Vertical Axis

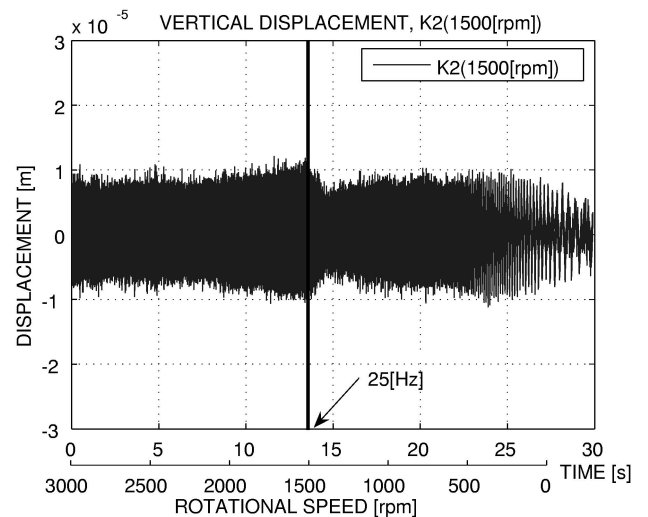

Fig. 5. Displacement of Vertical Axis

References

- (1) T. Sugie and Y. Tanai, " H_2/H_∞ Suboptimal Controller Design of Magnetic Levitation Systems(in Japanese)," *Trans. of the Society of Instrument and Control Engineers*, vol. 30, no. 10, pp. 1202 - 1208, 1994.
- (2) T. Namerikawa and M. Fujita, R.S. Smith and K. Uchida, "On the \mathcal{H}_∞ Control System Design Attenuating Initial State Uncertainties," *Trans. of the Society of Instrument and Control Engineers*, vol.40, no.3. pp.307-314, 2004.
- (3) W. Shinozuka and T. Namerikawa, "Improving the Transient Response of Magnetic Bearings by the \mathcal{H}_∞ DIA Control," *Proc. of CCA*, pp.1130-1135, Taipei, 2004.
- (4) C.R. Knospe and S.M. Tamer, "Robust Adaptive Control of Unbalance Response for a Flexible Rotor," *JSME International Journal - Series C*, vol. 40, no. 4, pp. 599-606, 1997.
- (5) Zi-he LIU, K. Nonami and Y. Ariga, "Adaptive Unbalanced Vibration Control of Magnetic Bearing Systems with Rotational Synchronizing and Asynchronizing Harmonic Disturbance," *JSME International Journal - Series C*, vol. 45, no. 1, pp. 142-149, 2002.
- (6) F. Matsumura, T. Namerikawa, K. Hagiwara and M. Fujita, "Application of Gain Scheduled \mathcal{H}_∞ Robust Controllers to a Magnetic Bearing," *IEEE Trans. on Control Systems Technology*, vol. 4, no. 5, pp. 484-493, 1996.